

TAMD 71A

**6-cylinder, 4-stroke, direct injected
turbocharged marine diesel with aftercooler**

Powerful, reliable and economical

- A high performance, long life engine built on the dependable in-line six design.
- Designed for
 - planing hulls with great demands on speed and acceleration characteristics.
 - semi-planing workboats in Medium duty operation
 - displacement workboats in Heavy duty operation
- Built for effective turbocharging with high output/fuel consumption ratio, thus achieving excellent fuel economy.
- Designed for easiest, fastest and most economical installation.
- Reduced white smoke emission during start and low load operation. Also reduced smoke emission during acceleration and heavy loads.
- Well balanced with steady and vibrationfree running for highest possible degree of boat comfort.
- Comprehensive programme of factory fitted equipment for perfect matching to specific customer requirements, e.g. reverse gears, PTO's, cooling systems, electrical systems.
- Simplified, thus time and cost saving, servicing. Well established service network in more than 100 countries using genuine parts and skilled personnel – minimizes non operational time and costs.

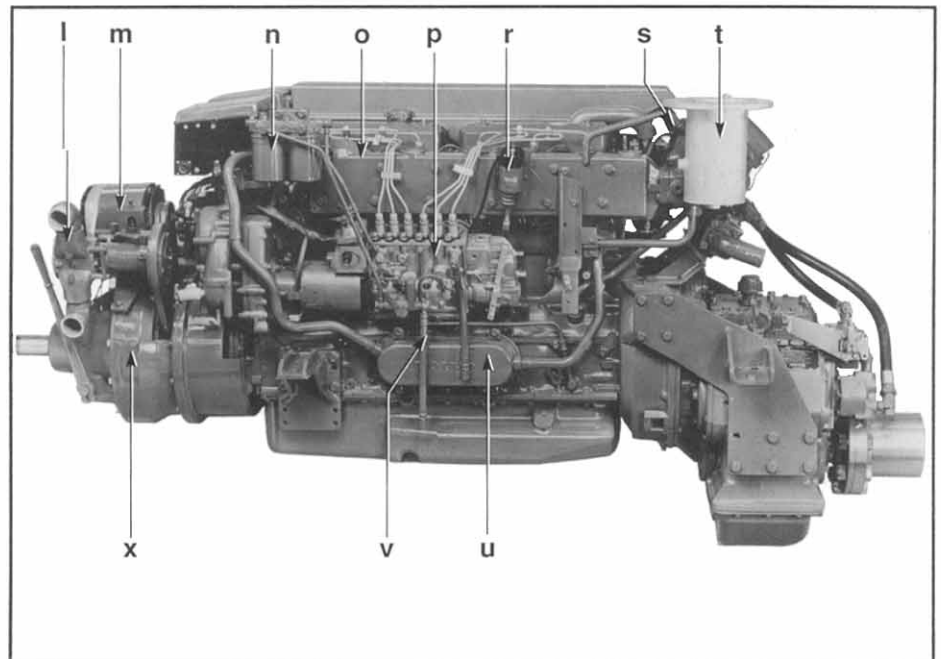
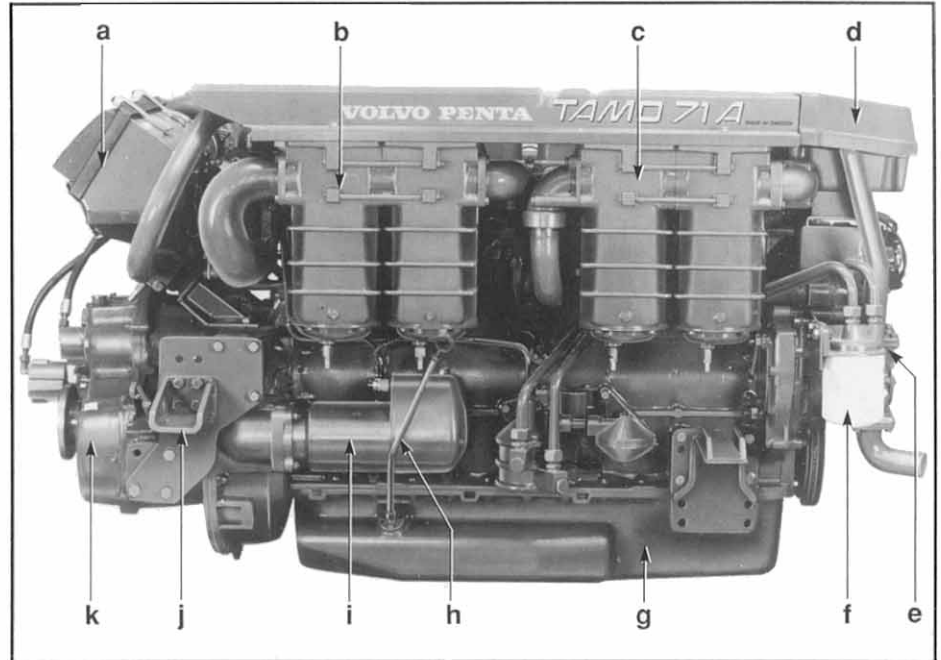

The engine shown is not an entirely standard unit.

**Optional*

- a. Air filter, paper type
- b. Aftercooler, watercooled
- c. Heat exchanger
- d. Thermostat housing
- e. Sea water pump
- f. Front mounted oil filter
- g. Oil sump
- h. Oil dipstick
- i. Starter motor
- j. Adjustable rear engine mounting
- k. Reverse gear*

- l. Flush pump*
- m. Extra alternator*
- n. Twin fuel filter
- o. Water cooled exhaust manifold
- p. Injection pump
- r. Stop solenoid
- s. Turbocharger
- t. Exhaust elbow, dry type*
- u. Oil cooler
- v. Oil dipstick
- x. Clutch*

**VOLVO
PENTA**

7734792 - Lastet ned fra www.volvopenta.com 25.09.2009 11:38:22

General data

Type designation	TAMD 71A
No of cylinders	6
Configuration	4-stroke direct-injected turbocharged and charge air cooled diesel engine
Fuel grade ASTM	1D or 2D
Bore, mm (in)	104.7 (4.12)
Stroke, mm (in)	130 (5.12)
Displacement, litres (in ³)	6.73 (411)
Compression ratio	14:1
Dry weight, kg (lb)	880 (1940)
Crankshaft output, ¹⁾ at crankshaft speed, r/min	
LD, kW (hp) (2500 r/min)	257 (350)
MD, kW (hp) (2500 r/min)	210 (286)
HD, kW (hp) (2000 r/min)	160 (218)
Torque ²⁾	
LD, Nm (ft, lb)	1000 (738)
MD, Nm (ft, lb)	821 (606)
HD, Nm (ft, lb)	778 (574)
Spec. fuel consumption ²⁾	
LD, g/kWh (lb/hph)	238 (0.39)
MD, g/kWh (lb/hph)	236 (0.38)
HD, g/kWh (lb/hph)	218 (0.35)

1) Technical data according to ISO 3046 Standard Fuel Stop Power. Fuel 25°C (77°F), lower calorific value of 42700 kJ/kg and density of 840 g/litre.

2) Torque and specific fuel consumption apply at the specified crankshaft output.

Standard equipment

Flywheel housing, flange size SAE 2
Expansion tank
Engine brackets
Freshwater cooled turbocharger and exhaust manifold
Watercooled aftercooler
Air cleaner, paper type
Fuel injection pump with centrifugal regulator and smoke limiter
Feed pump and double fine fuel filters
Oil filter of spin-on type
Fresh water cooled oil cooler
Electrical system 24 V, fully wired
Incl. alarms for oil pressure and temperature
Starter motor 24 V
Stop solenoid 24 V
Oil pressure and temperature sender units
Electrical terminal box
Pre heater element 24 V, incl. relay
Attachment for control cable, type 333 or 443

Technical features in brief

- Engine block and cylinder heads are iron castings.
- Replaceable cylinder linings and valve seats.
- The cylinder heads incorporate a flame barrier which protects the cylinder head gasket. The cylinder heads are tightened with 20 bolts.
- Oil cooled, forged pistons, reduces carbon deposits. Keystone rings minimize oil consumption.
- Waste-gate controlled turbocharger for the degree of boost, either through the aftercooler or, at low speeds, directly through the induction manifold.
- By-pass valve between the turbocharger and aftercooler – less white smoke on starting and low load operation.
- Identical matrix for heat exchanger and aftercooler make them fully interchangeable.
- Plug-compatible electrical system with complete wiring.
- Automatic induction air heating gives reliable low temperature starting.
- Gear wheel driven coolant pump and front mounted raw water pump allows easy service.
- Front mounted easy serviceable spin-on oil filter and filler.

Propeller shaft power according to ISO 3046

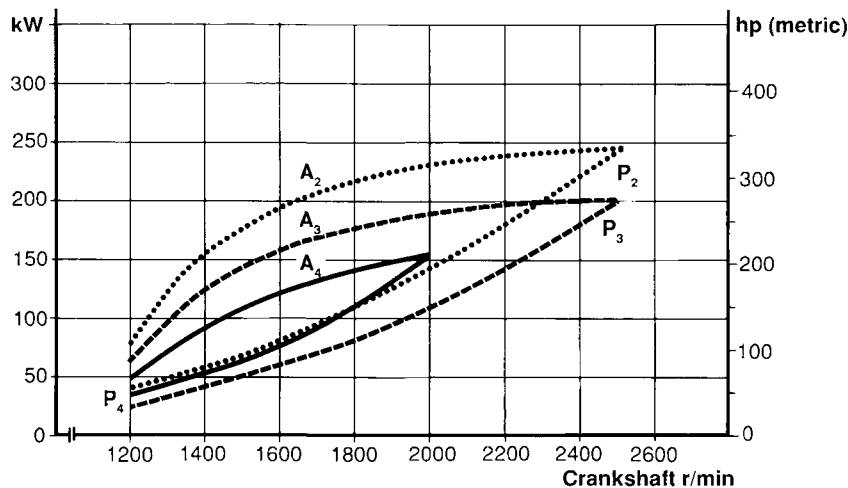

Propeller shaft power curves according to ISO 3046.

A₂=application LD
A₃=application MD
A₄=application HD

Calculated propeller load curves for fixed propellers.

P₂=exponent 2.5 (planing boats)
P₃=exponent 2.7 (semi-planing boats)
P₄=exponent 3.0 (displacement boats)

Fuel consumption diagram

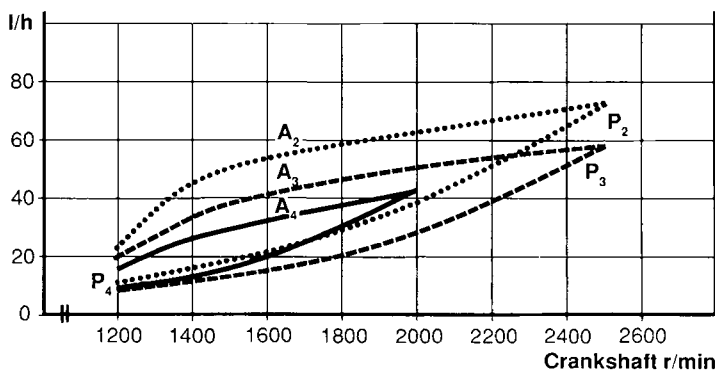

The curves in the fuel consumption diagram correspond to the power curves in the power output diagram.

Optional equipment TAMD 71A

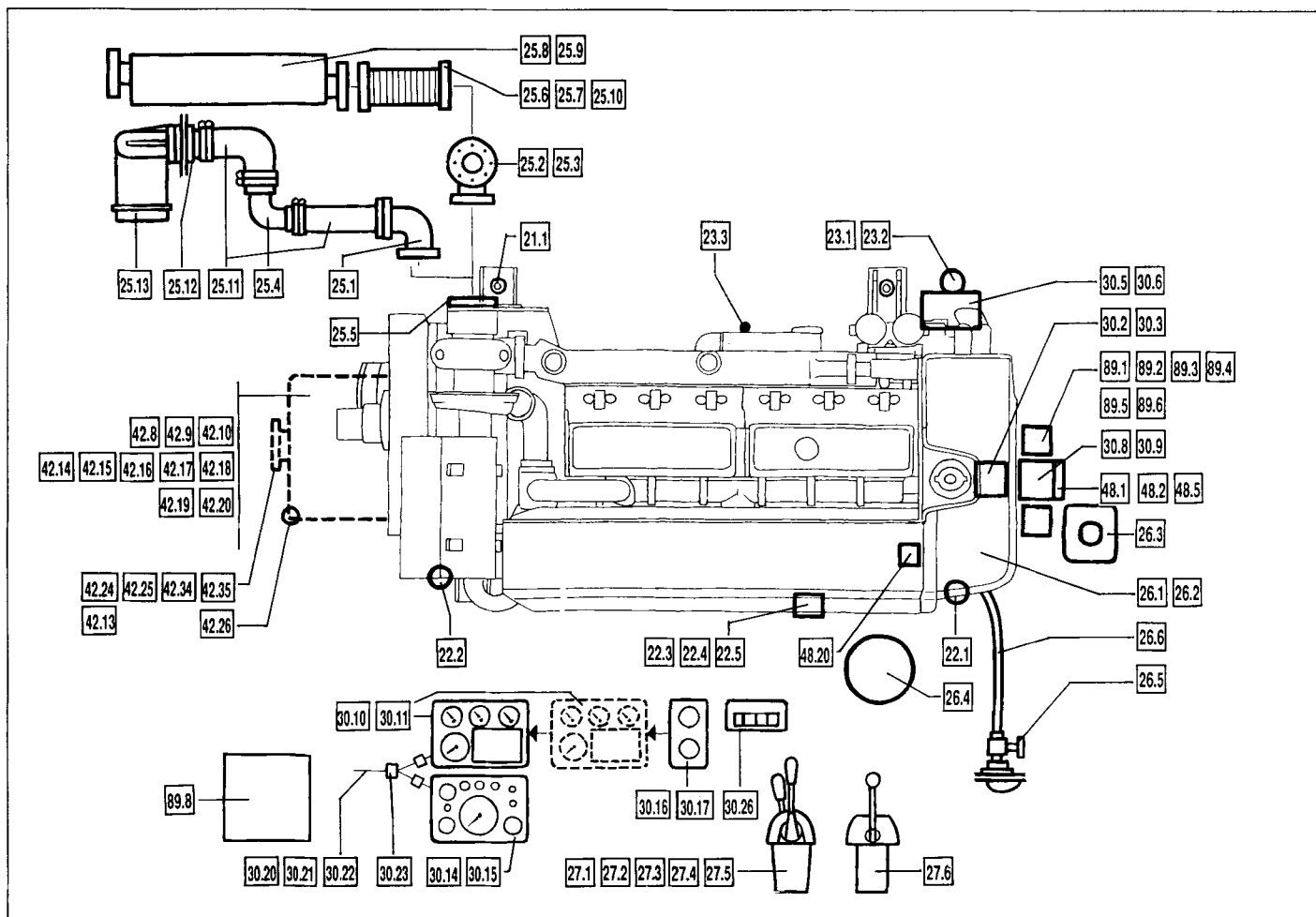

- | | | |
|---|--|---|
| 21.1 Flex. engine mounting, 4 rubber cush. | 27.4 Kit for dual station connection, cable 333 | 42.24 Prop. shaft flange for 42.14, 42.15, 42.16, 42.19, 42.20 |
| 22.1 Oil filter, by-pass. Front mounted | 27.5 Kit for dual station connection, cable 443 | 42.25 Prop. shaft flange for 42.17, 42.18 |
| 22.2 Oil filter kit, alternative mounting on rear end of engine | 27.6 Morse Control, model S | 42.26 Trolling valve, compl. for 42.14-42.20 |
| 22.3 Oil drain pump, manually operated | 30.2 12 V/50 A alternator, incl regulator | 42.34 Prop. shaft flange for MG 509 2.00:1-2.95:1 |
| 22.4 Do., electrical 12 V | 30.3 24 V/60 A alternator, incl regulator | 42.35 Prop. shaft flange for MG 509 3.83:1-4.50:1 |
| 22.5 Do., electrical 24 V | 30.5 12 V/130 A extra alternator, incl regulator. Shipped lose. | 48.1 Pulley for crankshaft front end Ø 158 mm. Four HC50 grooves. Ratio 1:1 |
| 23.1 Single fuel filter/water separator | 30.6 24 V/100 A extra alternator, incl regulator. Factory installed. | 48.2 PTO, front end. Rockford BW8" Ratio 1:1 |
| 23.2 Twin fuel filter/water separator with shift valve | 30.8 24 V/100 A extra alternator, incl regulator. Factory installed. | 48.5 PTO, front end. Rockford BW10" Ratio 1:1 |
| 23.3 Flexible fuel lines for engine | 30.9 Bracket for expansion tank | 48.20 Hydraulic pump, right hand front, facing backwards |
| 25.1 Exhaust elbow, watercooled, Ø 5" | 30.10 Main instrument panel, 12 V | 89.1 Flush/Bilge pump 1 1/4", 24 V |
| 25.2 Exhaust elbow, dry, Ø 4" | 30.11 Do., 24 V | 89.2 Flush+Bilge pump 107, module for double installations |
| 25.3 Exhaust elbow, dry, Ø 5" | 30.14 Instrument panel, 12 V for a second control station | 89.3 Flush/Bilge pump 2", 24 V |
| 25.4 Pipe bend for wet exhaust line Ø 5" 90° | 30.15 Do., 24 V | 89.4 Flush+Bilge pump 109, for twin install. |
| 25.5 Flange for turbocharger | 30.16 Extra instrument panel 12 V | 89.5 Connection parts for flush pump |
| 25.6 Flexible exhaust hose, dry Ø 4" | 30.17 Do., 24 V | 89.6 Connection parts for bilge pump |
| 25.7 Flexible exhaust hose, dry Ø 5" | 30.20 Cable harness 3.0 m (9.8 ft) | 89.8 Tool kit |
| 25.8 Silencer, dry, Ø 4" | 30.21 Do., 5.0 m (16.4 ft) | |
| 25.9 Silencer, dry, Ø 5" | 30.22 Do., 7.0 m (22.7 ft) | |
| 25.10 Compensator, dry Ø 4" | 30.23 T-connector | |
| 25.11 Exhaust rubber hose, Ø 5" for wet exhaust line | 30.26 Visual alarm display | |
| 25.12 Through hull fitting, Ø 5" for wet exhaust line | 42.8 Reverse gear TD MG 5061A 7° angle down 1.75:1 | |
| 25.13 Exhaust boot, rubber Ø 5", for wet exhaust line | 42.9 Do. 2.01:1 | |
| 26.1 Heat exchanger and sea water pump | 42.10 Do. 2.47:1 | |
| 26.2 Keel cooling equipment | 42.13 Prop shaft flange for MG 5061SC and 42.8-42.10 | |
| 26.3 Expansion tank, separate | 42.14 Reverse gear TD MG 507-1. 1.10:1 | |
| 26.4 Sea water strainer | 42.15 Do. 1.51:1 | |
| 26.5 Coolant water inlet with shut off valve | 42.16 Do. 1.98:1 | |
| 26.6 Hose for coolant water inlet | 42.17 Do. 2.54:1 | |
| 27.1 Twin control, Morse NB | 42.18 Do. 2.99:1 | |
| 27.2 Connection kit for control cables, type 333 | 42.19 Reverse gear TD 507A-1, 7° angle down 1.51:1 | |
| 27.3 Connection kit for control cables, type 443 | 42.20 Do. 1.98:1 | |

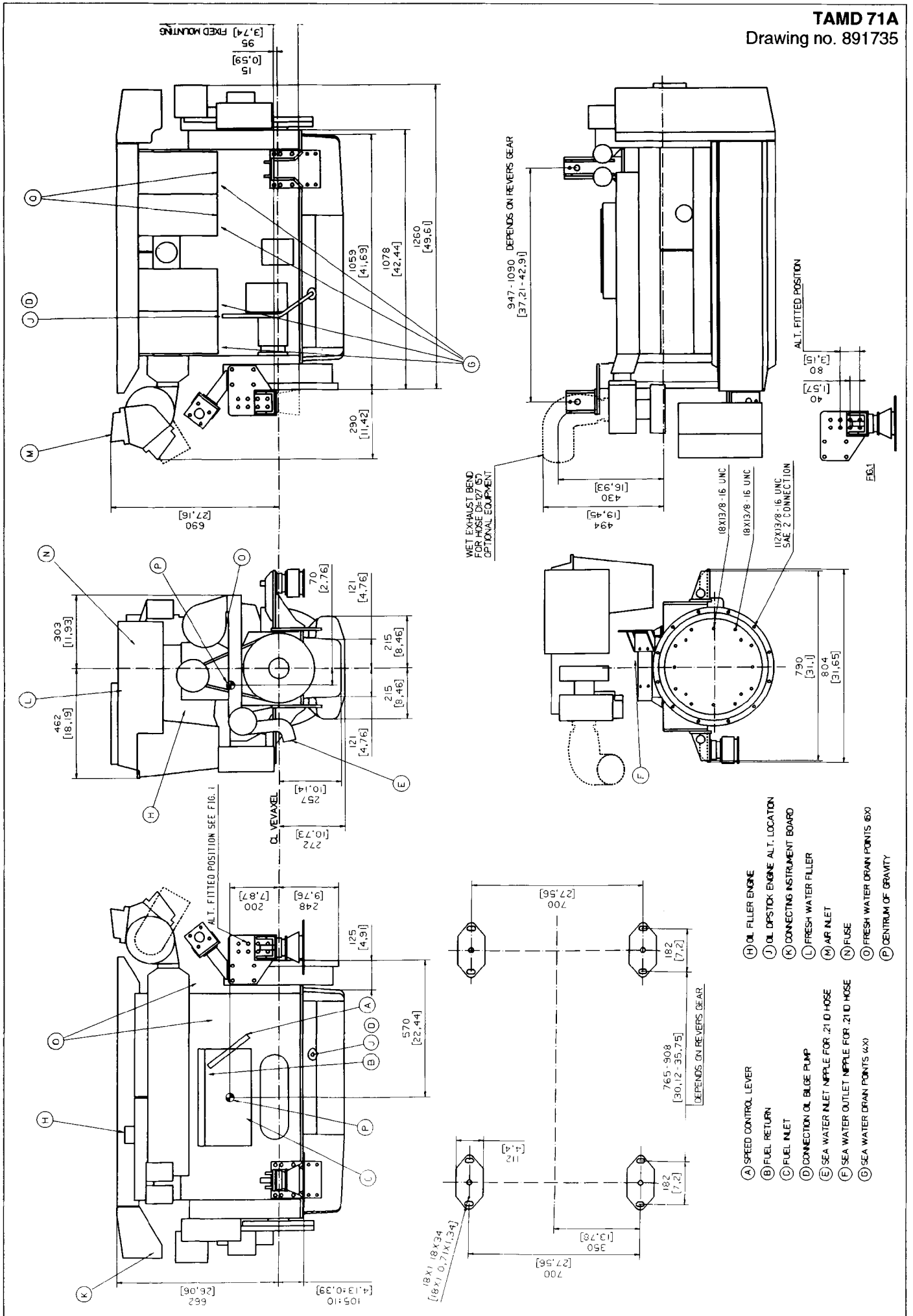

- (A) SPEED CONTROL LEVER
- (B) FUEL RETURN
- (C) FUEL INLET
- (D) CONNECTION OIL BLDGE PUMP
- (E) SEA WATER INLET NIFFLE FOR .21 D HOSE
- (F) SEA WATER OUTLET NIFFLE FOR .21 D HOSE
- (G) SEA WATER DRAIN POINTS (xx)
- (H) OIL FILLER ENGINE
- (J) OIL DPSTICK ENGINE ALT. LOCATION
- (K) CONNECTING INSTRUMENT BOARD
- (L) FRESH WATER FILLER
- (M) AIR INLET
- (N) FUSE
- (O) FRESH WATER DRAIN POINTS (x)
- (P) CENTRUM OF GRAVITY

7734792 - Lastet ned fra www.volvo-penta.com 25.09.2009 11:38:22